

# Jeep Wrangler

## HCE-RCAM-WRA

### Stealth-Mount Spare Tire Camera

### Quick Installation Manual

- Model: Wrangler
- Model Year: 2007-2018

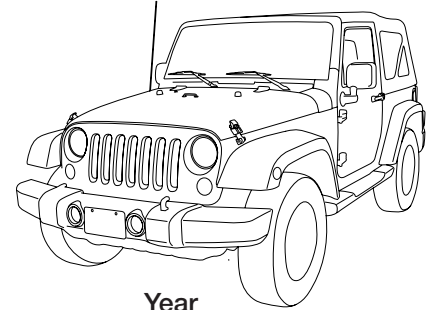

Jeep	Model	Year
	Wrangler (JK)	2007-2018
	Wrangler Unlimited (JK)	2007-2018

\* The specified vehicles have been tested and have met compatibility specs at the time of testing. Compatibility is not guaranteed if the manufacturer has made production changes to the listed vehicles above.

**⚠ Warning:** Before you begin wiring, remove the ground wire from the negative terminal of the battery. Failing to do so can lead to electric shock, injury or damage to equipment.

### Installation Kit Parts

- Camera Bracket W/HCE-C1100 x 1
- Spare Tire Bracket x 1
- Camera Extension Cable x 1
- Quick Installation Manual x 1
- Extra Nut For M6x12 Screw x 1
- Power & Video Unit x 1
- Water Proofing Adhesive Pad x 1
- Water Proofing Pad x 1
- Allen Wrench x 1
- Cable Ties x 5
- Retaining Clips x 3
- Heat Shrink Tube x 1
- Torx Screw & Lock Washer M6x8 x 1
- Torx Screw, Lock Washer, & Nut M6x12 x 1

### Factory Unit Disassembly (2007-2010 Only)

- 1) Remove top by releasing 2 rear clips on the back of the top panel and then pull panel forward.
- 2) Release 2 clips on the top of the bottom panel. This will expose two 7mm screws. Remove those.
- 3) Release 2 clips on the top of the bottom panel. This will expose two 7mm screws. Remove using a 7mm socket with ratchet & extension.
- 4) Use panel removal tool to remove dash panel by releasing 6 clips (3 per side).
- 5) Extract (4) 7 mm screws and remove the factory radio.

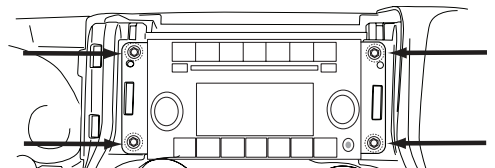

### Factory Unit Disassembly (2010-2018 Only)

- 1) Remove the rubber cover from the top center storage area and extract (1) 7mm screw.
- 2) Remove the knee cover panel and extract (2) 7mm screws located to the right and left sides of the steering wheel column.
- 3) Remove the window switch pod using a panel removing tool and extract (1) 7mm screw.
- 4) Remove the dash panel.
- 5) Extract (4) 7 mm screws and remove the factory radio.
- 6) Extract (2) 7 mm screws from the factory radio bracket and remove it.

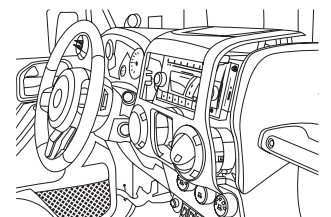

### Glove Box Removal

- 1) Open the glove box.
- 2) Push inwards both left and right sides to release the glove box out.

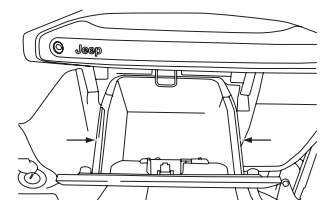

## Remove B-Pillar Panel

- 1) Remove B-Pillar panel by disengaging 4 clips on both front and rear passenger sides.
- 2) Using panel removing tool, unclip the B-Pillar. Be careful not to damage the panel.
- 3) Lift the carpet up on both front and rear passenger sides to expose the OEM cables.

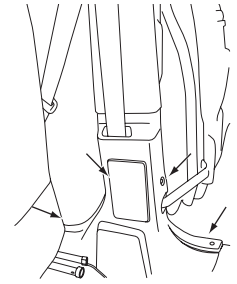

## Remove Right Side Panel

- 1) Using T25 Torx, remove the screws on the rear right side panel.
- 2) Using panel removing tools, pry off seatbelt cover and remove the roll cage cover.
- 3) Using 10mm socket to remove the panel.
- 4) Unclip the cigarette lighter socket from the harness.
- 5) Remove the Rear Right Side Panel.

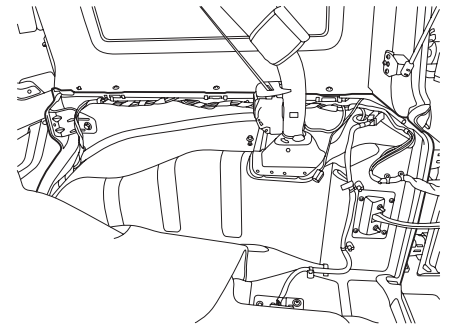

## Remove Spare Tire

- 1) Using 19mm socket, extract the lug nuts.
- 2) Using panel removing tools, unclip and remove wire cover on the rear gate.

## Bracket Installation

- 1) Attach camera bracket (which already uses the M6x8 & Lock Washer pre-assembled) to spare tire bracket using the supplied allen wrench, M6x12 torx screw, lock washer, and nut.
- 2) Adjust the bracket for the camera height.
- 3) Place bracket with camera over the studs and slide to the back. There's usually 2 on the top and 1 on the bottom.
- 4) Slide retaining clips over the studs to hold the bracket in place.
- 5) Check the spacing of the bracket by placing the spare tire back over the studs.
- 6) If spacing is correct use 19mm socket to re-install spare tire.

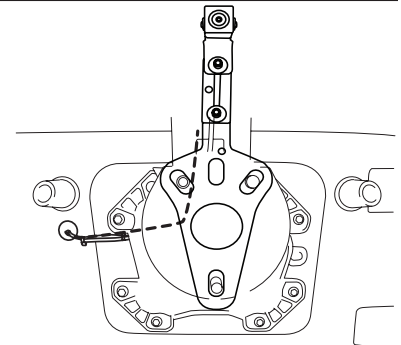

## Route Extension Cable And Power & Video Unit

- 1) Route the wires starting at the head unit, to behind the glove box, down the passenger kick panel, along the door sill, through the right side panel area, and along the factory door handle cable.
- 2) Secure the cables.
- 3) Go through factory grommet.
- 4) Run cables to camera.

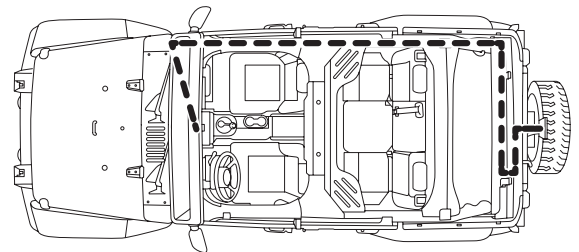

Download the full detailed version of the installation manual at [www.alpine-usa.com/support](http://www.alpine-usa.com/support).